

APTITUDE PAPER

FOR SCHOLARSHIPS TO BE AWARDED
IN SEPTEMBER 2009

WEDNESDAY 4th FEBRUARY 2009
DURATION 2 HOURS

INSTRUCTIONS TO CANDIDATES

You are required to answer **ONE** question only.

In your answers you should;

	Mark	Suggested Time In Minutes
a) Develop a full specification that offers supporting reasons behind each important point	15	20 mins
b) Produce at least three initial concepts, which demonstrate flair and imagination that relate to the specification. Candidates should identify the relative merits of the ideas introduced.	45	60 mins
c) Develop your preferred solution. You should address the following: <ul style="list-style-type: none"> ◆ Materials ◆ Construction ◆ Function ◆ Features ◆ Sizes/Dimensions 	30	40 mins
d) Demonstrate an organised, logical and well presented response.	10	
TOTAL MARKS	100	

ALL YOUR A3 ANSWER SHEETS MUST HAVE IN THE TOP RIGHT HAND CORNER

- ◆ Your name and school clearly printed
- ◆ The number of the question you have chosen to answer.
- ◆ The page number

**DO NOT TURN OVER UNTIL YOU ARE
INSTRUCTED TO DO SO**

ALL ANSWERS MUST CLEARLY SHOW ALL CONSTRUCTIONAL DETAILS, MECHANISMS AND/OR CIRCUITS.

QUESTION 1

Local authorities are encouraging householders to recycle increasing amounts of their domestic waste in order to meet government recycling targets. This requirement is part of an initiative to collect household waste on a fortnightly, rather than a weekly, basis.

As householders adjust to the fortnightly collection wheelie bins are often being filled to overflowing.

There is an opportunity to market a device that will allow householders to compact the contents of their wheelie bins. You are asked to design a device that can be quickly and easily fitted and removed. The device must provide a means of compacting the contents in the bin. The product must be robust in construction and be seen as a desirable accessory for the householder who is struggling to meet the changing waste collection practices.

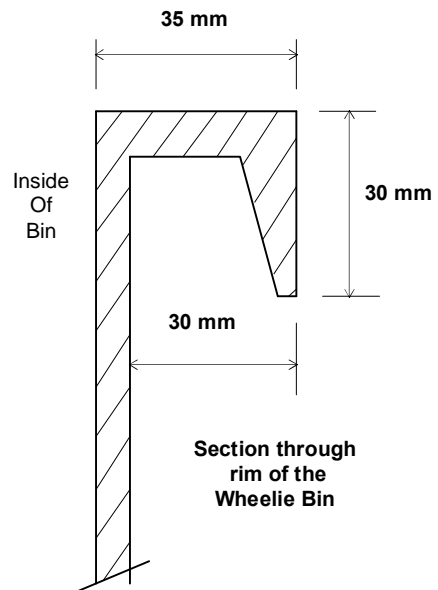

	Height	Width	Depth
240 ltrs	1070 mm	580 mm	740 mm

-----0-----

QUESTION 2

Your local table tennis club is hoping to improve the reaction times of its players by introducing a table tennis serving machine into their training routines. This will allow players to practice returns of serve without the requirement of having a training partner.

You are asked to design a machine that is capable of being programmed to deliver table tennis balls with varying speed, direction, height .

The machine should be capable of storing up to thirty balls and delivering them automatically to the projector system, serving them either when triggered by the player or in a random sequence.

Information on the ball delivery and projecting systems should be fully detailed. A low voltage power system is available to drive motors and compressors as required.



QUESTION 3

Building an extension or carrying out house improvements inevitably produces large amounts of waste. Hiring a skip is the typical way of disposing of that debris.

One of the difficulties is that skips usually have high, angled sides. This causes particular problems when trying to empty a wheelbarrow into the skip. The usual method, pushing the wheelbarrow up a narrow plank, is difficult and very dangerous.

You are asked to design a safe means of emptying a wheelbarrow into a skip that could be hired at the same time as the skip and used by the householder.

Although mains electricity is available should you wish to use it, an environmentally friendly system would be preferable.

Skip and wheelbarrow dimensions overleaf

Skip

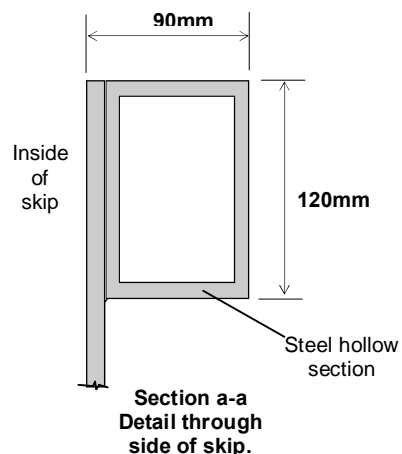
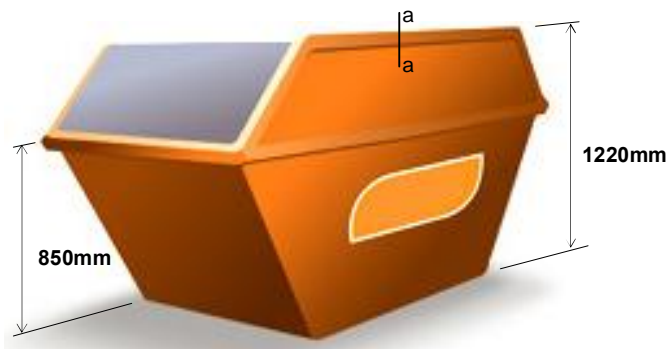

Cu. Mtrs	Height	Length	Width
6	1220 mm	3660 mm	1680 mm

Wheel Barrow

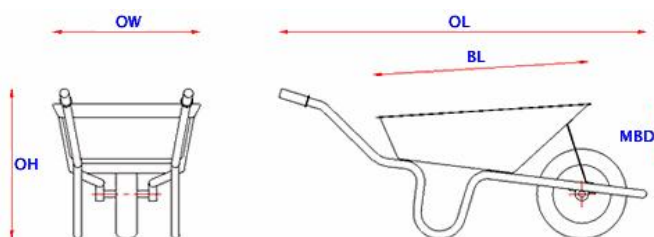

Width	OW	580 mm
Overall Height	OH	530 mm
Overall Length	OL	1440 mm
Body Length	BL	810 mm
Max. Body Depth	MBD	230 mm

The Arkwright Scholarships Trust
 Holly House
 74 Upper Holly Walk
 LEAMINGTON SPA
 Warwickshire
 CV32 4JL
 Tel 01926 333210
www.arkwright.org.uk

Registered Charity No 1091988
 Registered in England and Wales No. 4401993